

TOUR-T-TALL

Tour Series Mic Stand with Black Chrome Finish, Modular Base Design, and Quarter-turn Clutch
- Tripod Base/Tall Height

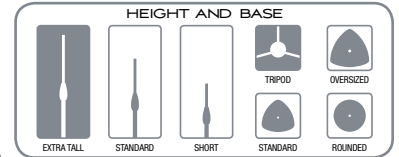

Modular Base Design

Any Tour Series base (three tripod, three weighted) fits any Tour Series shaft (short, standard, and tall) so you'll always be prepared for whatever the next show demands. And the Tour Series bases feature super aggressive threads combined with a wedge lock that allows for a much faster setup and take down.

Black Chrome Finish

Featuring a hard chrome protective finish (5x more durable than the finish found on stadium bleachers, for example), Tour Series mic stands will not chip, rust, or show wear - period.

Heavy-duty, Secure Clutch

The patented Quarter-Turn Clutch on the Tour Series microphones is a super smooth design that locks and unlocks with only a quarter turn of the clutch handle. It's an over-molded clutch that delivers a secure grip that locks up faster and smoother than any other clutch on the market.

Patented Universal Mic Attachment

Whether you're performing in the States or over seas, a Tour Series microphone stand is the only stand you'll need. The top threads fit both US- and metric-threaded mic clips and accessories for use all around the world.

100% Field-replaceable Parts

All Tour Series microphone stands can be field serviced with replacement parts as needed over their VERY long lifespan (from the foot caps all the way up to the mic adapter).

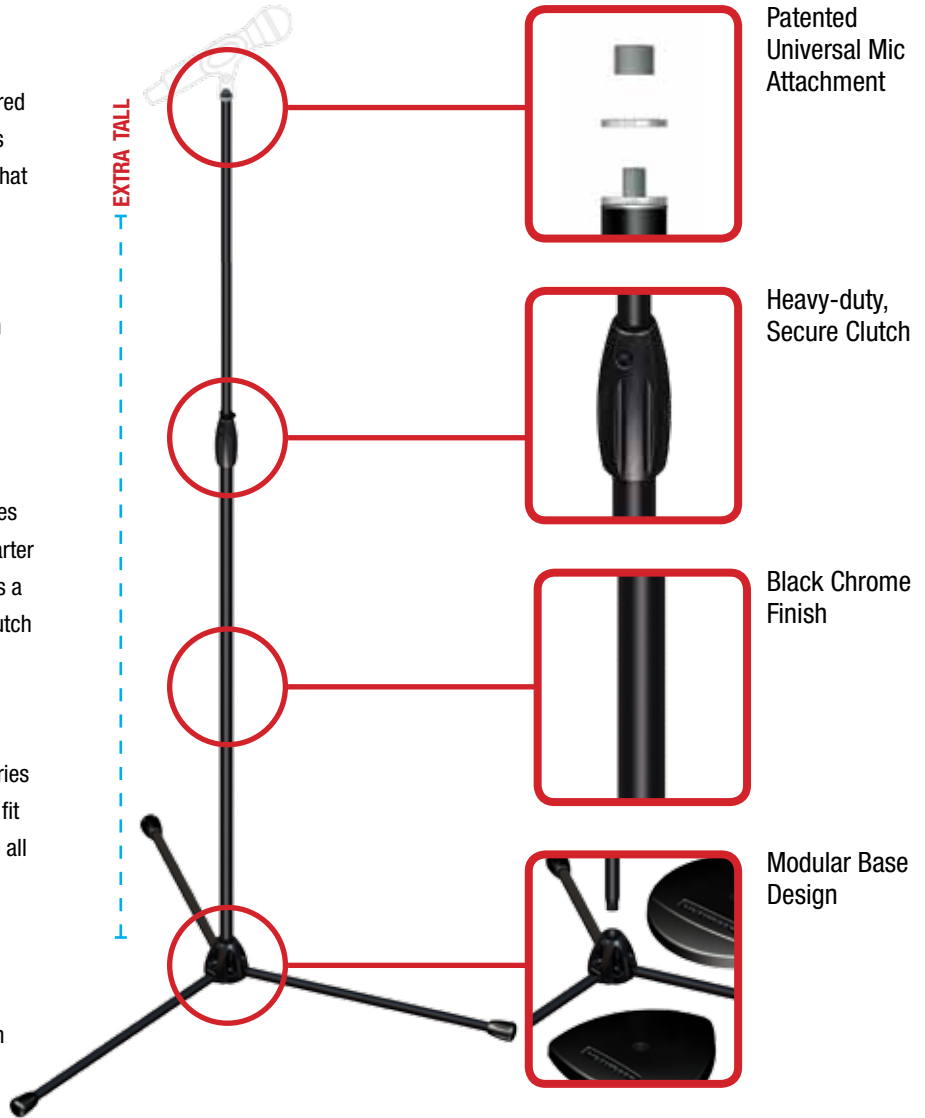

TOUR-T-TALL SPECS

- TOUR-T-TALL #17193 — black chrome
- Height 55.1" - 96.5"
(1400 mm - 2450 mm)
- Tube diameter 1.1" (28 mm)
- Base Footprint: 42" x 42"
(1067 mm x 1067 mm)
- Weight 13.8 lbs.

Base footprint:

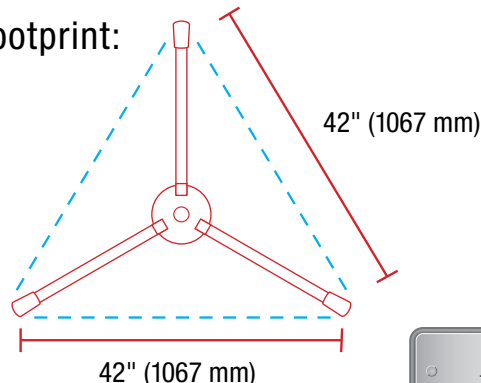

R. 1.1, 10/25/2011, 1S-ULT-TOUR-T-TALL



TOUR SERIES

The **Tour Series mic stands from Ultimate Support** are the perfect solution for the professional tour company, high-end venue, and serious musician. With oversized, heavy-walled steel tubing and a black chrome finish, they are the strongest, most durable mic stand built for the road. They also feature a modular design so you can choose any of the six bases to combine with any of the shaft heights for the perfect mic stand depending on your needs from night to night. Finally, all Tour Series mic stands are 100% completely field serviceable, so you can replace parts if they fail, instead of the entire microphone stand. Tour Series mic stands set a new standard for anything your next tour can throw at them.



TOUR-T

Tour Series tripod base mic stand - standard height.



TOUR-T-TALL

Tour Series tripod base mic stand - extra tall height.

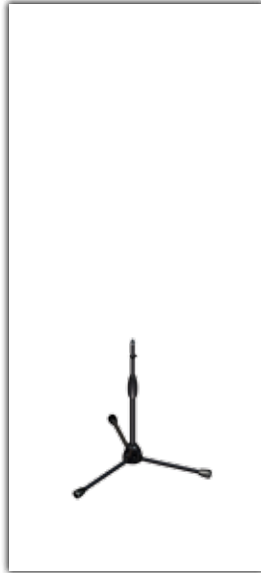

TOUR-T-SHORT

Tour Series tripod base mic stand - short height.



TOUR-MT

Tour Series standard weighted base mic stand - standard height.



TOUR-LT

Tour Series oversized weighted base mic stand - standard height.



TOUR-RB

Tour Series round weighted base mic stand - standard height.



TOUR-T-T

Tour Series Package - tripod base mic stand with telescoping boom - standard height.



TOUR-T-TALL-T

Tour Series Package - tripod base mic stand with telescoping boom - extra tall height.

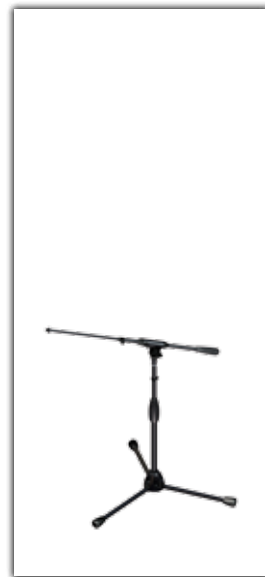

TOUR-T-SHORT-T

Tour Series Package - tripod base mic stand with telescoping boom - short height.

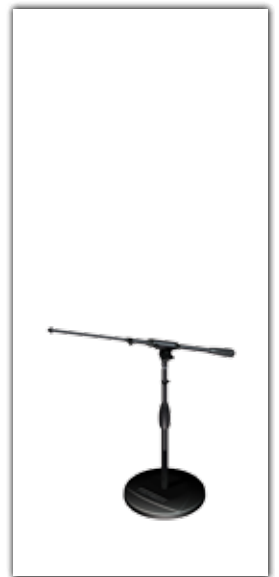

TOUR-RB-SHORT-T

Tour Series Package - round weighted base mic stand with telescoping boom - short height.

