

LIVE-T

Live Series Microphone Stand with One-handed Height Adjustment, Durable Lightweight Aluminum Construction, and Tripod Locking Legs

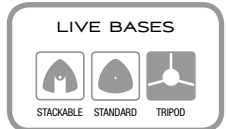

One-handed Height Adjustment

Designed as the perfect performance stand, the new Live Series one-hand clutch holds better than any other one-hand stand. New ergonomic handle feels great in your hand and is easy to use - just squeeze to easily raise or lower the microphone.

Durable, Lightweight Aluminum Construction

Live Series microphone stands are designed with the lead singer in mind. They're light enough to move from gig to gig, but robust enough to take whatever you can throw at them. Durable, anodized aluminum construction creates a strong, ultra-lightweight stand preferred by lead singers.

Available With Three Different Bases

The Live Series mic stand is available with one of three base configurations. The Live-T features a locking tripod mechanism that locks legs in place for stable performance and fold up and locks for compact transport (simply turn the locking ring on the base to unlock legs and open). The Live-ST features a sturdy, die-cast standard weighted base while the stackable Live-SB combines the stability of a weighted base with the ability to stack six of them in the same space as just one!

Patented Universal Mic Attachment

Whether you're performing in the States or over seas, a Live Series microphone stand is the only stand you'll need. The top threads fit both US- and metric-threaded mic clips and accessories for use all around the world.

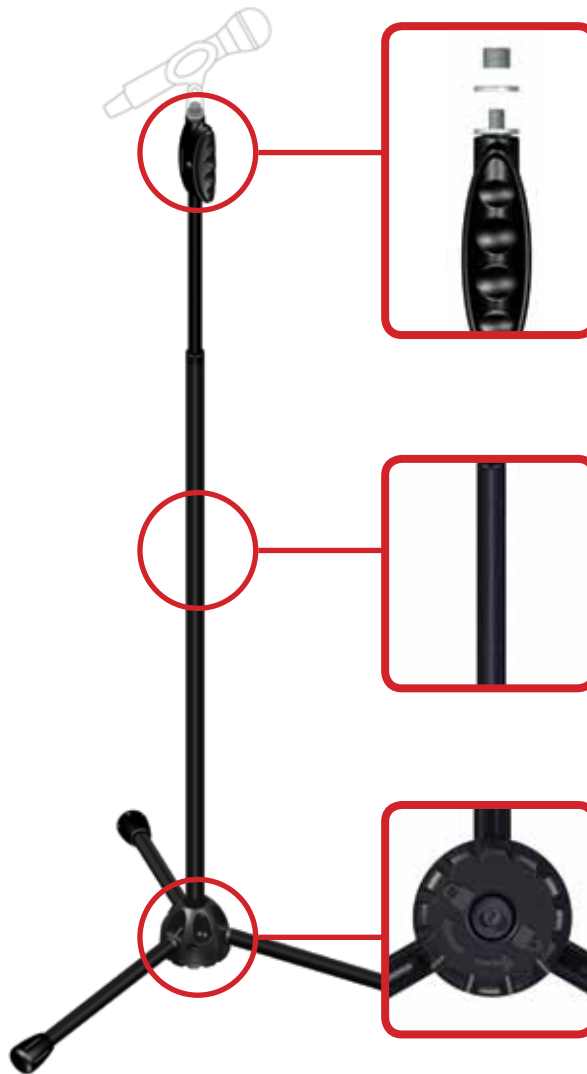

Top threads fit both US and metric threaded mic clips and accessories. The Ergo clutch feels great. It easily raises or lowers the microphone height with just one hand.

Durable, lightweight aluminum construction.

Lock legs in place for stable performance then fold up and lock for compact transport.

LIVE-T SPECS

- LIVE-T #17204—black
- Height 45.3" - 74.8"
(1150 mm - 1900 mm)
- Tube diameter 1" (25 mm)
- Weight 4.2 lbs.
- Base footprint 25" x 25"
(610 mm - 610 mm)

Base footprint:

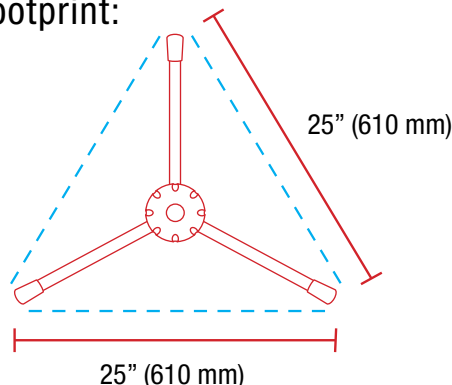

R. 1.1, 11/07/2011, 1S-ULT-LIVE-T



LIVE-SERIES

Ultimate Support invented the one-hand height adjustable microphone stand nearly two decades ago. The Live Series mic stands are intended to make the life of the musician easier with a super ergonomic clutch that easily raises and lowers to a desired height with just one hand. Plus, Live Series mic stands are constructed from super strong, lightweight aluminum so they're able to take the demands of today's musicians but light enough to go anywhere. Available in three base options (tripod, weighted, and stackable), there's a Live Series microphone stand that's perfect for your needs!

**LIVE-SB**

Stackable Weighted Base

**LIVE-T**

Locking Tripod Base

**LIVE-T**

Standard Weighted Base